

INSTRUCTION MANUAL



KEPCO An ISO 9001 Company.

**KIT
DIN FAW
-100P, -150P**

DIN-RAIL MOUNTING KIT FOR SERIES FAW 100W, 150W

DESCRIPTION. Kepco KITS, Models DIN FAW-100P, and -150P each contain a cover, a mounting bracket with left and right preassembled mounting clips and associated hardware used to install FAW Series power supplies on a DIN rail. The -100 suffix is for the 100 Watt Series and -150 for the 150 Watt Series. The "P" suffix is for mounting the power supply perpendicular to the DIN rail as shown in Figure 1. Outline Dimensions are shown in Figure 5

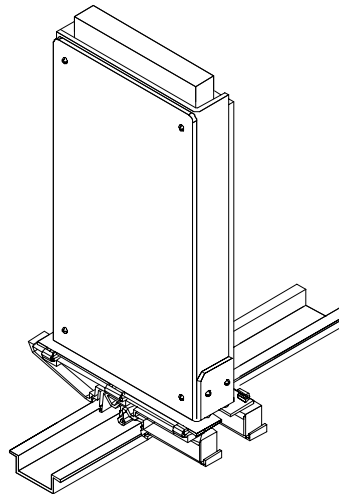

3041753

FIGURE 1. P SUFFIX ORIENTATION

TABLE 1. COMPONENTS SUPPLIED

KIT MODEL NO.	COVER PART NO.	MOUNTING BRACKET PART NO.	SCREW (QTY 6) (Power Supply To Mounting Bracket) PART NO.	WASHER (QTY 6) (Power Supply To Mounting Bracket) PART NO.	CLIP (QTY 2) PART NO.	CLIP PLATE (QTY 2) PART NO.	SCREW Thread form (QTY 4) (Clip To Mounting Bracket) PART NO.	WASHER (QTY 4) (Clip To Mounting Bracket) PART NO.
DIN FAW-100P	CA 27	128-1952	101-0092 (4-40 X 5/16 BHPH)	103-0014 (NO. 4, INT. TOOTH)	108-0362	128-1938	101-0443 (4-40 X 1/4 BHPH)	103-0014 (NO. 4, INT. TOOTH)
DIN FAW-150P	CA 28	128-1953	101-0092 (4-40 X 5/16 BHPH)	103-0014 (NO. 4, INT. TOOTH)	108-0362	128-1938	101-0443 (4-40 X 1/4 BHPH)	103-0014 (NO. 4, INT. TOOTH)

KEPCO, INC. ● 131-38 SANFORD AVENUE ● FLUSHING, NY. 11352 U.S.A. ● TEL (718) 461-7000 ● FAX (718) 767-1102

<http://www.kepcopower.com> ● email: hq@kepcopower.com

INSTALLATION

1. **INSTALL COVER.** Attach the cover to the power supply per instruction manual supplied with the cover.
2. **INSTALL MOUNTING BRACKET.** Attach the mounting bracket to the power supply using the hardware supplied (see Figure 2).

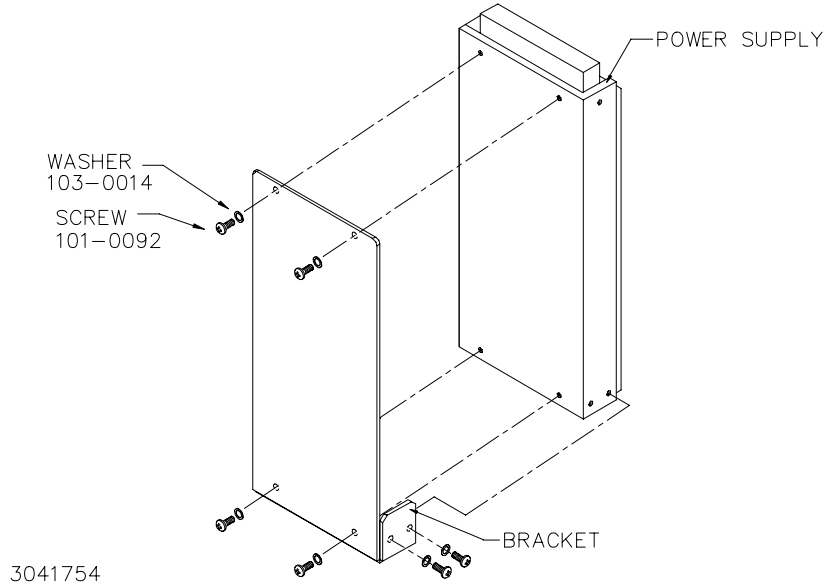

FIGURE 2. INSTALLING MOUNTING BRACKET ON POWER SUPPLY

3. **INSTALL CLIPS.** Attach preassembled mounting clips into the mounting bracket holes using hardware supplied (see Figure 3).

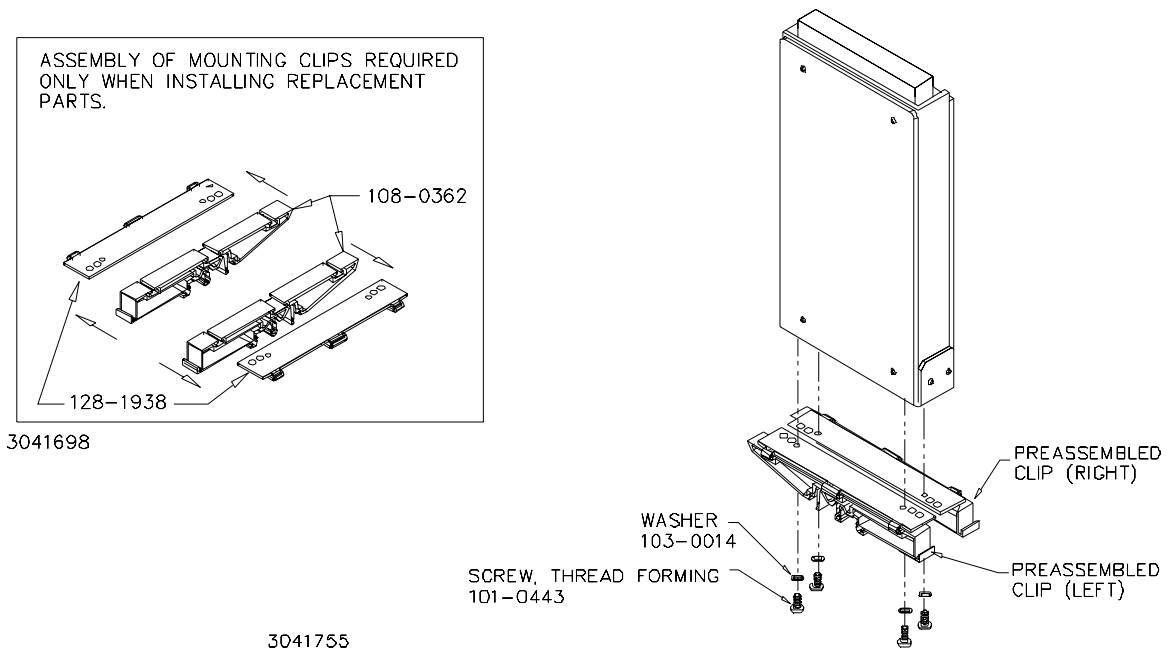
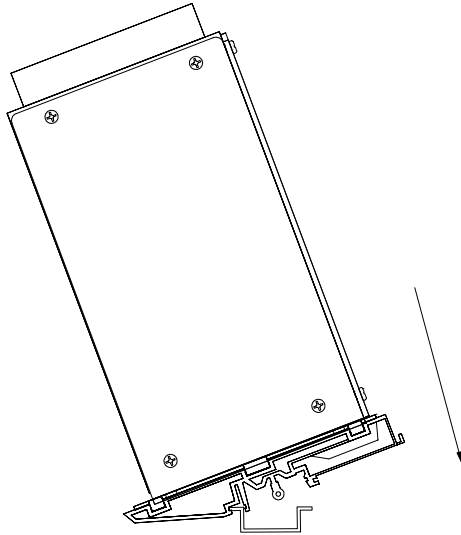

FIGURE 3. INSTALLING CLIPS ON MOUNTING BRACKET

4. **INSTALL POWER SUPPLY ON DIN RAIL.** To mount the power supply on the rail insert one end of both mounting clips under one edge of the rail, then snap the other end of the two clips into place (see Figure 4A).

A INSTALLATION



B REMOVAL

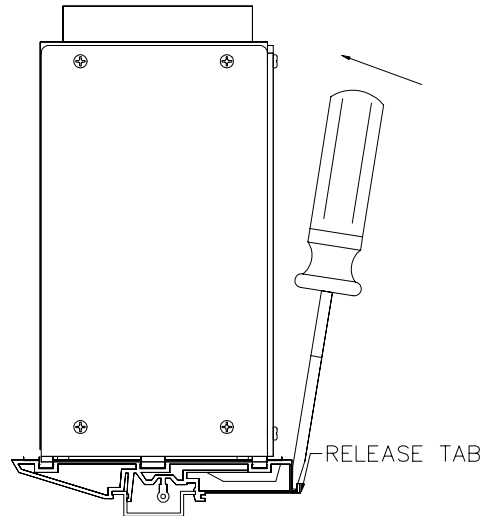

3041756

FIGURE 4. INSTALLATION AND REMOVAL OF POWER SUPPLY FROM DIN RAIL

REMOVING POWER SUPPLY FROM DIN RAIL. While grasping the power supply with one hand, Insert a screwdriver into the access holes provided and apply leverage towards the left as shown in Figure 4B to disengage each clip from the rail. Where mounting clips are close together, it may be necessary to apply leverage with two screwdrivers simultaneously.

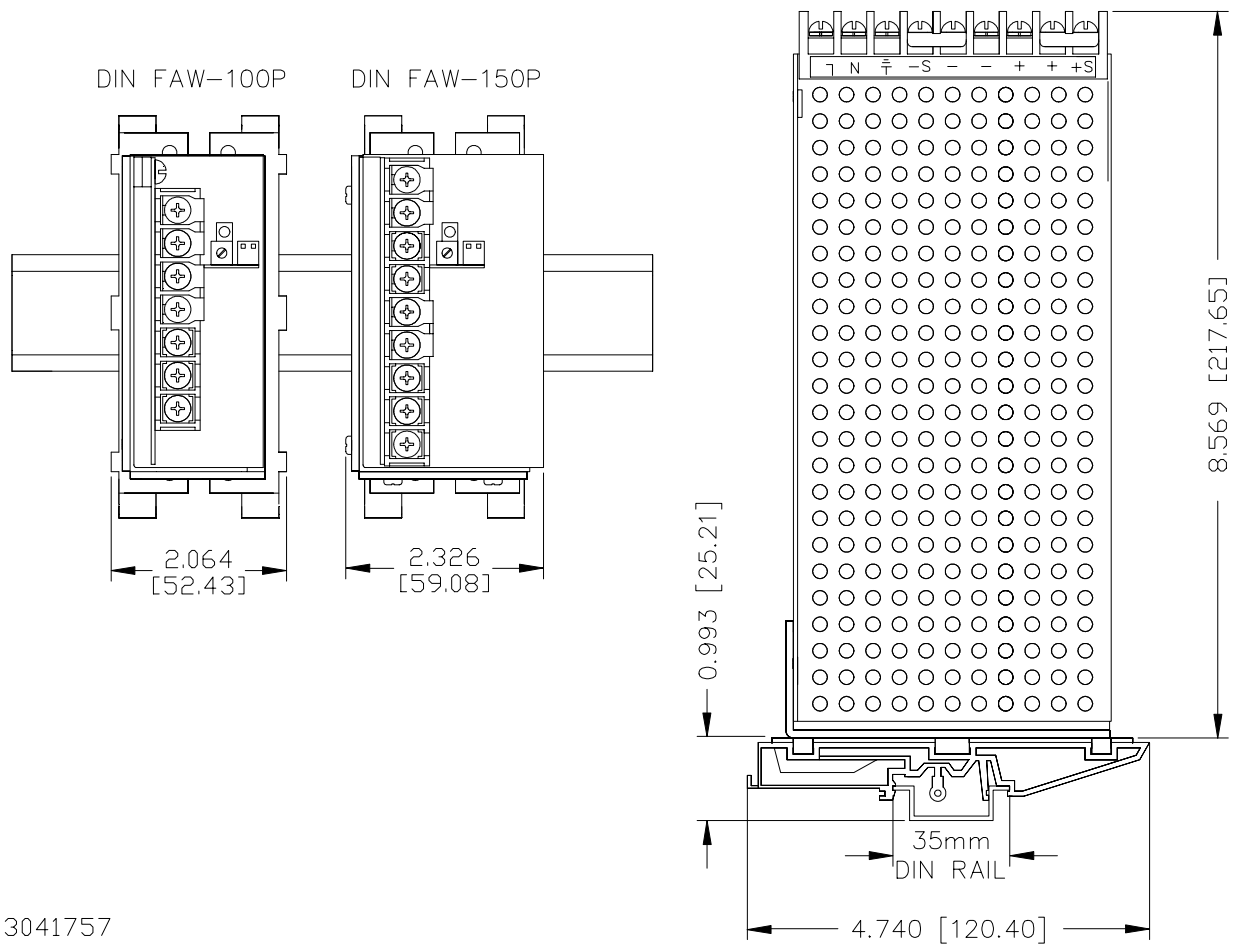

3041757

FIGURE 5. FAW 100W, 150W POWER SUPPLY WITH KIT INSTALLED, OUTLINE DIMENSIONS